

Salter Industries, Spiral Stair

Adjustable Stair Installation Instructions

TOOLS NEEDED:

1. Electric drill with hex chuck and Phillips bit
2. Drill bits 1/8", 1/4", 3/16", 3/8"
3. Socket Set
4. Tape Measure
5. Short magnetic level or 2' Level
6. Hack Saw
7. Hammer
8. Saber Saw or Reciprocating Saw with a metal cutting blade
9. Allen Wrenches

Required minimum finished well size. See shop drawings for other specified dimensions.

3'6" 4' 4'6" 5' 5'6" 6' 6'6" 7'
44" x 44" 50" x 50" 56" x 56" 62" x 62" 68" x 68" 74" x 74" 80" x 80" 86" x 86"

Range of adjustment for stairs that have a 30 Degree Tread or the Half Turn Packages

Minimum Riser	Maximum Riser	Required Treads	Risers	Degree Rotation
85"	95"	9	10	270 Degree
93 1/2"	104 1/2"	10	11	300 Degree
102"	114"	11	12	330 Degree
110 1/2"	123 1/2"	12	13	360 Degree
119"	133"	13	14	390 Degree

Range of adjustment for stairs that have a 22 1/2 Degree Tread

Minimum Riser	Maximum Riser	Required Treads	Risers	Degree Rotation
82 1/2"	93 1/2"	10	11	225 Degree
90"	102"	11	12	247 1/2 Degree
97 1/2"	110 1/2"	12	13	270 Degree
105"	119"	13	14	292 1/2 Degree
112 1/2"	127 1/2"	14	15	315 Degree

Calculate the riser height: (an equal measurement of space between each tread).

- A. Measure your finished floor to floor height in inches.
- B. Count the number of treads supplied in the kit and add 1 to that number.
- C. Divide the floor to floor height by the number of risers counted.
- D. Most spiral stairs will have a riser height between 8 1/2" to 9" . See what was specified on your order form.

EXAMPLE: 108 " floor to floor height divided by (11 treads + 1 riser up to the platform = 12 risers) so 108" divided by 12 risers = 9" riser height. A 9" space will between each tread.

If you have difficulty determining the effects of putting the oak treads over the steel treads, just rest the wooden treads on the stair during the assembly.

WARNING: Oak handling and finishing.

Unfinished treads and handrails on the job site for more than one week absorb moisture from the air. They must be sealed. Plastering, tile work, cement or brickwork introduce enough water into the air for the wood to react unfavorably. If the materials need to be placed in storage, find a cool, dry and stable location.

- A. Sand all wood surfaces before applying any stain or polyurethane. Nearly 100% of tread and handrail finishing problems occur because little or no final sanding is done at the job site prior to application of stain or polyurethane. Treads rub together or against surfaces during handling and transportation. This creates shiny spots, which will not absorb finishing material evenly. Wood can absorb moisture, raising the grain and ruining any finish applied without being sanded.
- B. Sand all wood surfaces with 100 to 220 grit.
- C. Apply a stain if you want the color of the wood other than a natural finish.
- D. Three coats of sealer must be applied to all surfaces of the wood. Inadequate finishing of all **six** sides of a tread including the bottom will permit the absorption of moisture.

IMPORTANT NOTE: Check with your paint specialty dealer for complete finishing instructions.

Steel stair finishing

The paint applied to the steel stair is considered a primer coat. If a mark was made in the finish due to shipping and handling, sand that spot prior to finishing. We have seen very good results from both brushed and sprayed applications. We suggest that you apply a coat of paint prior to your assembly, if the timing is available. If you use spray paint, spray several thin coats. This will provide a smooth and uniform finish. Use an oil base paint such as **Rust-Oleum** or **Krylon** semi-gloss finish for best results.

We have not painted the center column because the paint can be seriously scratched when the treads are slid over the center column.

IMPORTANT NOTE: Paint has been changing chemically in the last few years because of the V.O.C. laws. It is impossible for Salter's to guarantee that all paint brands are compatible with our primer. If you are concerned with your paint being compatible with our primer, try a test spot to make certain there is no chemical reaction between the paints. Also, check that your paint will have good adhesion for chip resistance. For further information contact your local paint specialist.

NOTE: Steel, Galvanized Steel, Aluminum and Forged Iron Stairs are assembled using the same procedure. The primary variation is the assembly hardware.

STOCK ADJUSTABLE SLEEVES

Whether you purchase our standard steel stair, our aluminum stair or our Forged Iron stair the assembly process is very similar.

1. While all the treads are on the ground, partially thread the setscrews into the tread and platform sleeves.
2. Stand the center column up in the opening.
3. Slide all the treads over the center column. All the treads are the same.
4. Slide the platform over the center column. Use the 5/16" x 2" lag screws and washers supplied and attach the platform in the desired location.

IMPORTANT NOTE: If the steel platform is going to be covered with 1 1/16" oak or 3/4" flakeboard, lower the steel platform by that thickness. **You want the finished platform cover to be flush with your finished floor.**

IMPORTANT NOTE: If you have purchased extra railings from us, the location of the platform is critical to the well enclosure railings fitting. Do a dry fit of the railings before permanently fastening the platform.

You may find that your opening in the floor is not perfectly square. To center the stair and maintain the most finger and knuckle room from any surrounding walls, you may shim the platform. When you are installing the stair off a balcony face, you may want to push the stair further from a lower wall.

5. Plumb the center column and attach the base plate to the floor with the 5/16" x 1 1/2" lag bolts and washers supplied. If you are installing this on concrete, you will need to purchase lead anchor shields.

6. Start the installation with the top tread. Place a baluster in the hole closest to the platform. Attach the baluster to the tread with the 1/4" x 1 1/2" carriage bolt, nut and lock washer supplied.

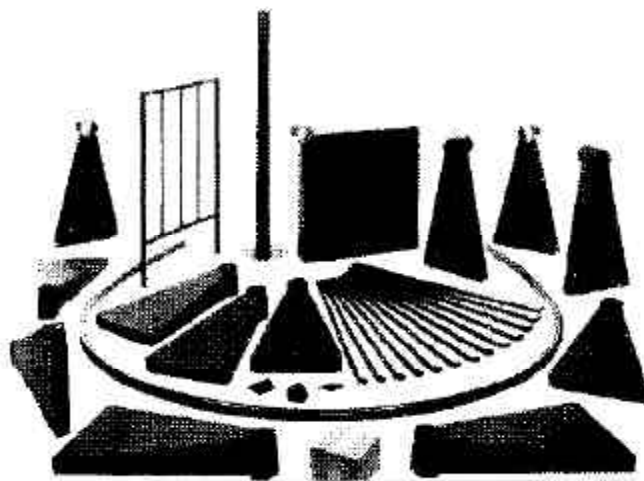

IMPORTANT NOTE: Make sure that the bottom of all the balusters are at the same depth in the lower tread pocket. Use your finger to feel that it is flush with the bottom of the tread support.

IMPORTANT NOTE: Be certain that you start the rotation the same way as it was ordered. Wood, aluminum and brass handrails are rolled to a specific rotation.

7. Move the top tread with the baluster attached, to the proper riser height required.

IMPORTANT NOTE: On the top tread only, if you are going to have a wood tread cover, lower the steel tread by that thickness. After this, all your steel tread to steel tread heights will be the same.

8. Plumb the baluster and attach the top baluster to the face of the platform using the top baluster bracket.

9. Check that the tread is level and that the baluster is plumb. Tighten the 5/16" set screws to lock the tread in place.

IMPORTANT NOTE: Always tighten the baluster hardware first; check that the baluster is plumb and then tighten the setscrews last.

IMPORTANT NOTE: If you have purchased wood tread covers from us, make certain that you are able to get them on after the steel balusters have been installed. Otherwise you will need to install the steel treads and the wood treads together.

10. Lift the next tread to its proper height. Slide a baluster in the front hole of the upper tread and the back hole of the lower tread.

IMPORTANT NOTE: Always tighten the baluster hardware first; check that the baluster is plumb and then tighten the setscrews last.

11. Continue this procedure with the remainder of the treads.

12. The bottom baluster will only have one pre-drilled hole. Attach the bottom baluster to the tread. Plumb the baluster and attach the bottom baluster bracket to the floor with the 5/16" lag bolts

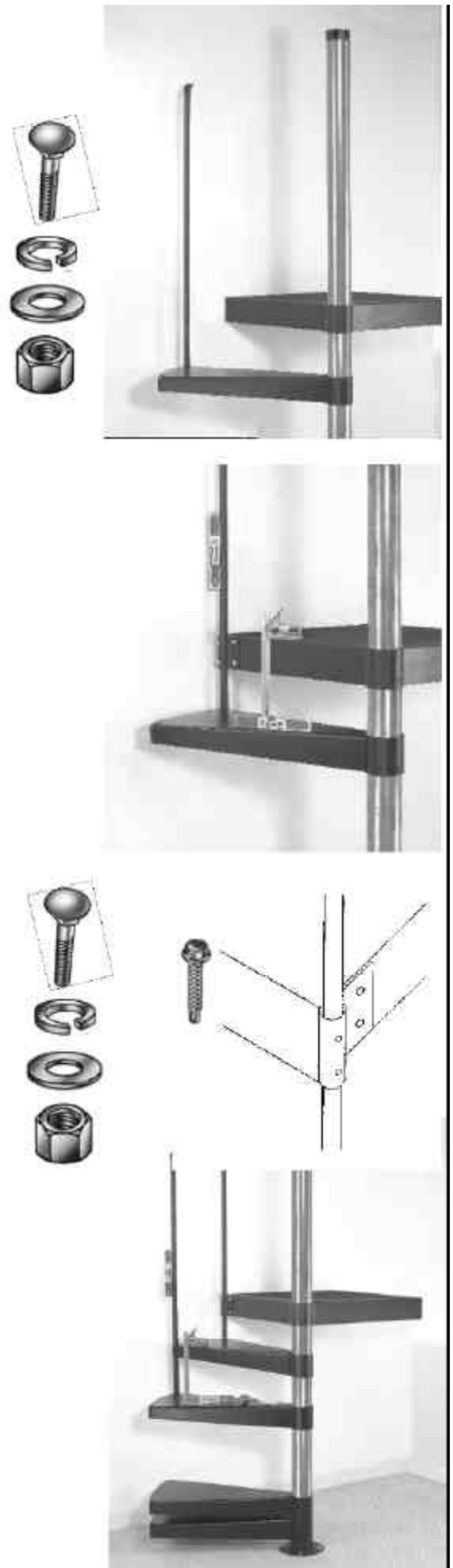

supplied. Once again make certain that the baluster is plumb.

IMPORTANT NOTE: Measure the baluster length. The length from the top of the steel tread to the tip of the baluster should be the same as all the other balusters.

13. Attach the handrail to the balusters with the hardware supplied.

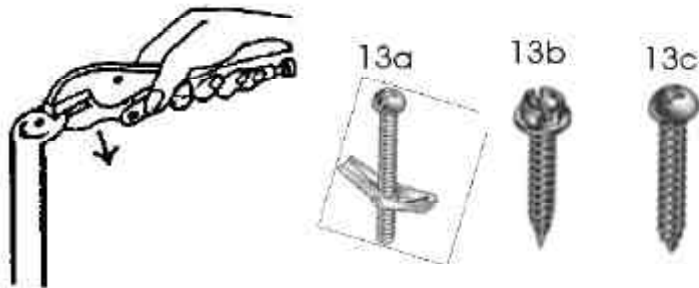

Vinyl Handrail

13 A. The vinyl handrail is shipped in a flat coil but can easily be formed to the shape of the stair. To install this handrail, use the toggle bolts supplied. Drill a 3/8" hole in the handrail to properly fasten the handrail to the baluster tip. After the handrail is fastened, cut the railing 3" above the top baluster and 3" below the bottom baluster, **unless your building code calls for a longer length.** Slip the vinyl railing caps over the ends to complete the installation.

IMPORTANT NOTE: If the baluster tips are not set at the proper angle for the handrail to lay flat, place an adjustable wrench over the tip and press up or down for the desired angle.

IMPORTANT NOTE: Do not apply paint to the vinyl handrail.

IMPORTANT NOTE: Check each baluster for plumb as you install the handrail. If you do not watch this you can push them out of plumb.

Brass & Aluminum Handrail

13 B. The brass or aluminum handrail has been shipped pre-formed but will need to be fine tuned during the installation. Since the material is very soft, it makes it easy to fine tune. Notice that the rail is kinked at each end. This is normal and should be cut off as excess after installation.

a.) Working with **two people**, start at the top and fasten the handrail to the top three or four balusters with the self-piercing screws supplied. As you work your way down, you will need to fine-tune the

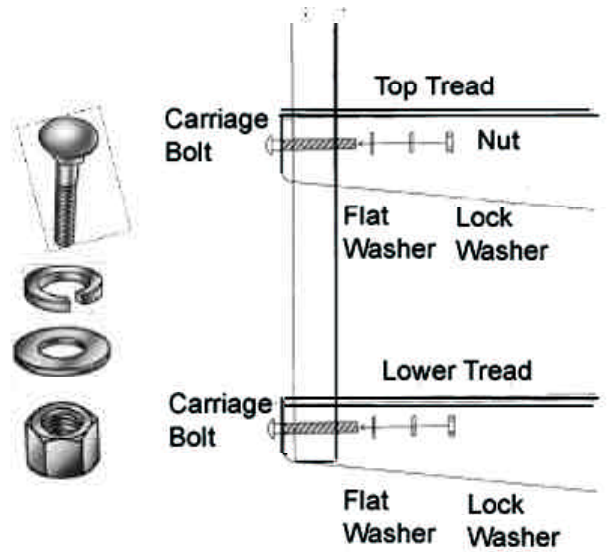

rail to match up to the baluster tip. To do this, you will need to push or pull the rail into place.

b.) After all the balusters are attached, cut the railing 3" above the top baluster and 3" below the bottom baluster, **unless your building code calls for a longer length**. Cut the handrail off square. File the burrs and insert the handrail plugs to check for fit. After the fit is correct, use the two-part epoxy supplied for final connection.

IMPORTANT NOTE: If the baluster tips are not set at the proper angle for the handrail to lay flat, place an adjustable wrench over the tip and press up or down for the desired angle.

IMPORTANT NOTE:

Check each baluster for plumb as you install the handrail. If you do not watch this you can push them out of plumb.

Oak Handrail

13 C. The oak handrail has been shipped pre-formed and is made to the shape of your stair. To fasten the handrail to the baluster tips, drill a pilot hole into the handrail and make the final connection with the wood screws supplied. The railing is shipped longer than needed and we suggest that you install the rail and cut it to length before staining and finishing it. Cut the railing 3" above the top baluster and 3" below the bottom baluster, **unless your building code calls for a longer length**. Remove the handrail from the stair and apply the desired finish.

IMPORTANT NOTE: The handrail needs to be sealed. This will prevent moisture from penetrating the wooden surface, which can cause checking (cracks in the wood). See the warning at the beginning of the instructions for further details.

IMPORTANT NOTE: If the baluster tips are not set at the proper angle for the handrail to lay flat, place an adjustable wrench over the baluster tip and press up or down for the desired angle.

IMPORTANT NOTE: Check each baluster again for plumb as you attach the handrail in place. If you do not watch this, you can push them out of plumb.

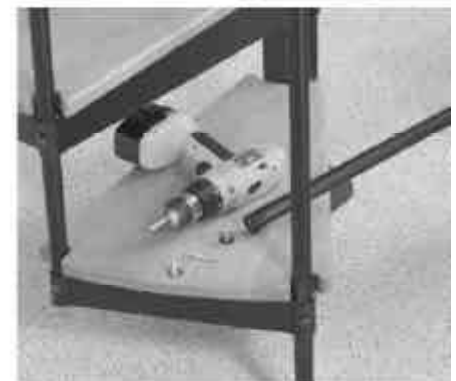

14. Install your **pre-finished** wood tread covering. Wood tread covers are connected to the steel tread with the # 10 pan head wood screws in the pre-drilled holes provided.

IMPORTANT NOTE: The wood treads need to be sealed and finished before they are connected to the steel treads. This will prevent moisture from penetrating the wood surface, which can cause checking (cracks in the wood). See the warning at the beginning of the instructions for further details.

Center baluster installation

15. Center balusters are designed to close the space between the two primary balusters. Consult your local building inspector for the required maximum spacing. Most states now require a space not to exceed 4".

The installation of center balusters is done after the handrail and wood treads are installed. There are several methods that are used to install center balusters depending on the type of finished tread surface. Refer to the drawing that applies to your tread type to determine the proper hardware needed. In all cases the center baluster needs to be cut to length in the field by the installer. A saber saw or a reciprocating saw, with a metal cutting blade will trim the balusters nicely.

A. Oak treads and diamond patterned steel treads are pre-drilled and ready to receive the center baluster. Smooth steel tread and flakeboard treads will require the installer to locate and drill mounting holes for the center balusters.

B. Place the baluster tip against the handrail as done with the primary baluster. Be certain that the baluster is plumb. Mark and cut the baluster to its proper length. Be certain that your cut is square. Connect the baluster to the tread and handrail with the appropriate hardware.

IMPORTANT NOTE: Do not assume that all the center balusters will be the same length. Cut them to length as needed.

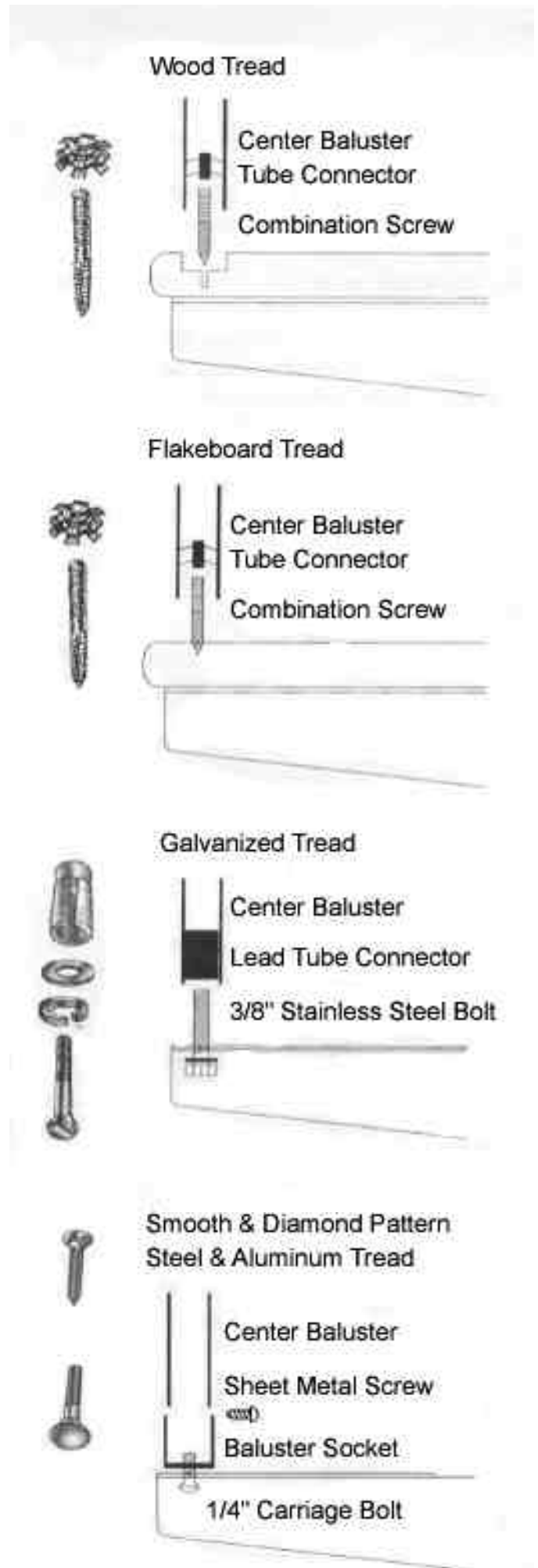

IMPORTANT NOTE: If your installation uses the combination wood screw, machine screw, take note. This fastener can be inserted into the chuck of your cordless drill. Chuck the screw at the center of the fastener. Chuck the screw at the center of the fastener. Be careful not to damage the threads. Press the tube connector into the end of the center baluster after the baluster has been cut. The tube connector will only press in one direction. Thread the center baluster over the combination screw and fasten the baluster tip to the handrail, as done on the previous primary balusters.



Classic Platform Railing

16.) The platform rail can be attached to any side of the platform. It is easiest to hold the rail in place with two C clamps, if available. Drill the platform with the rail clamped in place using a 5/16" bit. Fasten the rail in place with the hardware supplied.

IMPORTANT NOTE: If the platform rail is not plumb, you may place a flat washer between the railing and the platform to act as a shim.

If you have additional questions about the installation please call 610-489-5799

